

MM-160-TG



DESCRIPTION

Stainless steel Clear-Thru extraction arm for wall or ceiling mounting. 2m/7ft or 3m/10 ft length, 160mm/6.25" diameter with 3 flexible external joints.

Complete with mounting bracket for wall/ceiling mounting.

The spun stainless steel hood can be angled in any direction and is fitted with a safety mesh screen.

All metal parts are made from 316L stainless steel. The flex hose at the joints is a clear food grade polyurethane material with internal stainless wire reinforcement.

This style extraction arm has four adjustable friction joints and Clear-Thru design with no internal parts.

The shoulder and elbow joints are made from PA6 plastic and are located on the outside of the arm.

The MM-160-TG arm is shipped assembled, field attachment of the wall bracket necessary.

Recommended for airflows of 450cfm/ 800m³/h through 850cfm/1450m³/h

TECHNICAL DATA

Product Number	All models	MM-160-2-TG	MM-160-3-TG
Length:		2m / 7ft	3m / 10ft
Tube / hose diameter:	160mm / 6,25"		
Duct / hose connection:	160mm / 6,25"		
Hood diameter:	300mm / 11,75"		
Materials:	316L Stainless steel PA6 plastic Polyurethane hose		
Weight:		15Kg / 33 lbs	18Kg / 40 lbs
Maximum Temperature:	80°C / 175°F		
Wall mounting bracket:	Standard		
Air volume	450cfm/ 800m ³ /h @ 2000fpm/10,5m/s through 850cfm/1450m ³ /h @ 4000fpm/20m/s.		

PLYMVENT®

HANDLING AND OPERATION

Handling

1. Hand grip for the hood/arm.
2. Easy-to-reach external support mechanism.

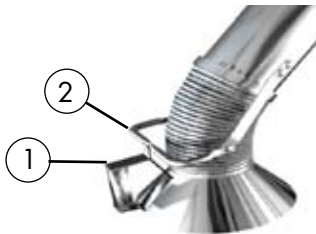

Hood operation

Stainless steel hood can be angled 65° to the side, 75° forwards and 120° backwards.



MEASUREMENTS AND PRESSURE LOSS

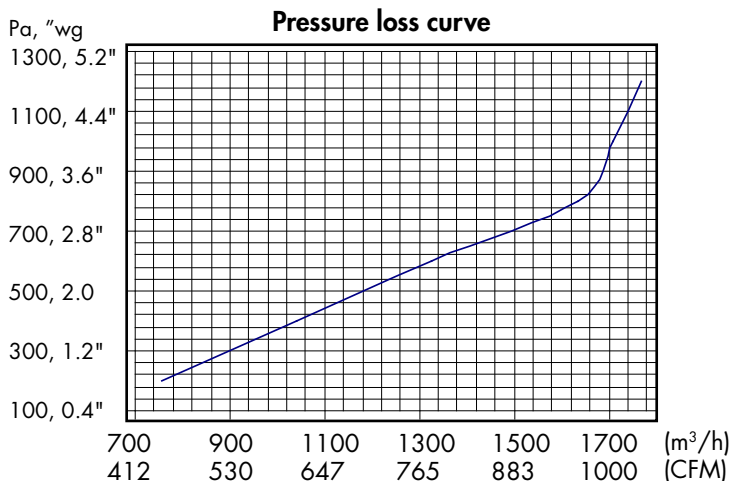
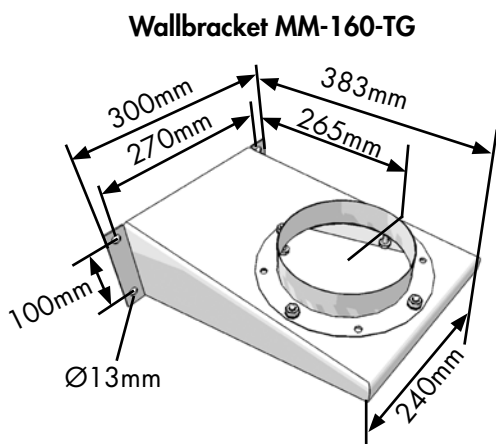
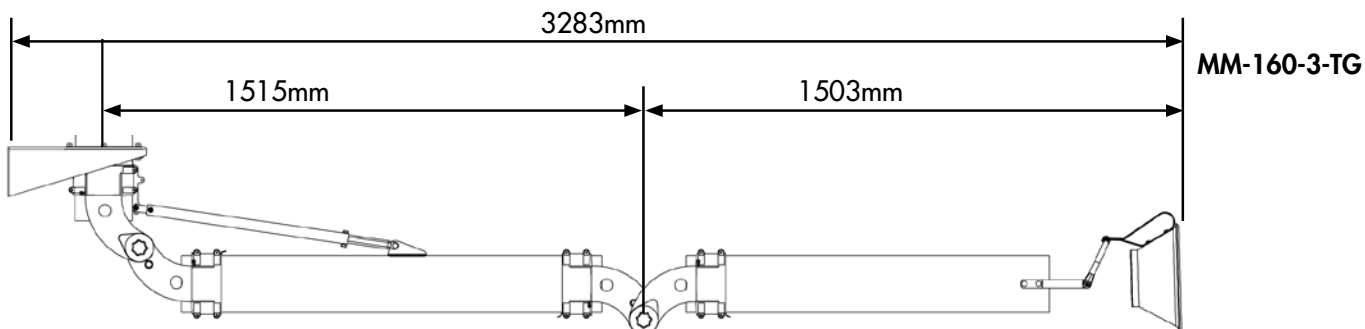
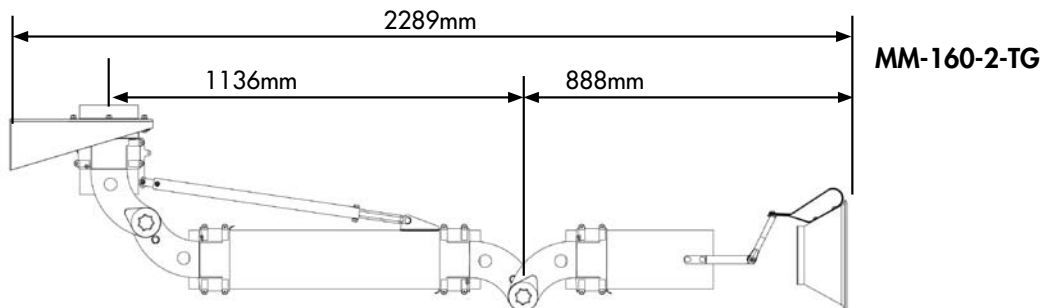

PLYMOVENT®

PlymoVent AB
 Industrigatan 26
 SE-212 14 Malmö, Sweden
 Tel: +46 40 30 31 30
 Fax: +46 40 30 31 40

www.plymovent.com info@plymovent.com

PlymoVent representative